



01 Series

# SELECTOR PACK MT01SP

## OPERATION MANUAL



 **MINITOR CO., LTD.** JAPAN

Head Office : 16-3 Ryogoku 1-chome, Sumida-ku, Tokyo 130-0026 JAPAN Phone 03-3633-7181 Fax 03-3633-7186  
Osaka Br. : 4-4 Itachibori 2-chome, Nishi-ku, Osaka 550-0012 Phone 06-6531-5300 Fax 06-6531-5417  
Nagoya Br. : 4 Kanayamacho 1-chome, Atsuta-ku, Nagoya 456-0002 Phone 052-671-3077 Fax 052-671-3177

<http://www.minitor.co.jp>

●Specifications and configurations are subject to change without notice.

20091007 IME-MT01SP

 **MINITOR CO., LTD.** JAPAN

## Contents

1. Safety Precautions	1	7. Connection of Control Pack	12
2. Equipment Features	3	7-1 Connection of Selector Connection Cord	
3. Specifications and Dimensions	3	7-2 Fixing of Connecting Cord	
3-1 Specifications		7-3 Connection of Selector Communication Cord	
3-2 Dimensions of External Appearance		7-4 Connection of Spindle Connection Cord	
3-3 Accessories		7-5 Connection Diagram of Entire Configuration	
4. Names and Functions of Each Component	5	8. Mounting of Bracket	15
4-1 Overall Configuration		9. Replacement of operation panel	16
4-2 Details of Operation Panel		9-1 Change of Mounting Direction of Operation Panel	
5. Operating Procedure	7	9-2 Replacement of Operation Panel and Filter Panel	
5-1 Type of Operation Mode		9-3 Cleaning of Filter	
5-2 Panel Operation Mode		10. Error Number Display	17
5-3 Panel/Remote Operation Mode		10-1 How Error Number Is Displayed	
5-4 Remote Operation Mode		10-2 When Malfunctions Are Detected	
5-5 Setting of the Function		10-3 Error Numbers and Their Contents	
5-6 Initialization of the Setting Content			
6. Connection of AC Power Cord	11		

Thank you for buying the SFIDA 01 series Selector Pack MT01SP. When using this equipment, a Motor Spindle and Control Pack are necessary. Read this Operation Manual and Operation Manual for the robot/NC machine tools etc., to understand all of its functions. Keep this operation manual in a safe place and read it when required.

## 1 Safety Precautions

### Definitions of Warning Symbols

In this manual, symbols are used to highlight warnings and cautions for you to read so that accidents can be prevented. The meanings of these symbols are as follows:



**Warning**

This symbol indicates explanations about extremely dangerous matter. If users ignore this symbol and the matters appearing in this manual, serious injury or death by fire or electric shock could result.



**Caution**

This symbol indicates explanations about dangerous matters. If users ignore this symbol and the matters appearing in this manual, bodily injury and damage to the equipment could result.



### Warning

- This device shall be grounded using the ground wire of the AC power cord. Make sure that the ground wire is connected to the earth to avoid an electric shock when using this device. In addition, confirm that the ground wire has been grounded correctly before connecting a cable to this device.
- If any malfunctions such as smoke, peculiar smells and/or sounds are present, turn off the main switch and unplug the power supply immediately. Consult an electrician for repair after confirming that all smoking has stopped. If the machine is damaged and used without proper repair, fire and electric shock could result.
- Do not attempt to modify or disassemble the machine since this can cause serious loss in performance and safety; otherwise, fire and electric shock could result.
- Be sure to only use the input voltage specified in this device since fire and electric shock could result.
- Do not block ventilation openings since this can result in a failure or fire from heat.
- Do not put Control Pack on unstable locations such as a shaky stand or a leaning surface, etc. If it falls or topples over it can cause injury.
- Do not use this device under an environment where corrosive gas (chlorine gas, hydrogen sulfide, sulfurous acid gas, etc.) is present, because it may lead to an unexpected failure of parts.
- When the AC power cord or plug is damaged, replace it with the normal cord(option). Continuous use may cause fire and/or electric shock.
- To prevent the risk of fire and electric shock, do not plug or unplug the machine from the AC outlet with wet hands.
- Wear safety protective glasses to protect eyes and an anti-dust mask to prevent inhalation of debris. You may suffer from unexpected injuries caused by flying debris generated through use of this machine.



### Caution

- Operate machinery in a dry location free of condensation, otherwise this could result in a fire and/or electric shock.
- Operate in temperatures of 0~40°C.
- When installing do not block the filter panel where cool air is taken in or the exhaust ventilation slits.
- Do not allow children to operate machinery by any means; keep machine out of their reach.
- Do not hit or drop objects on the device as this may damage it.
- Be careful so that dust, oil and water do not enter the device. When foreign substances such as liquid enter the device, turn off the main switch, unplug the power supply from the AC outlet and consult with a qualified technician. Fire and electric shock could result if used as is.
- Do not place heavy objects on the power cord as this may damage the cord resulting in a fire and or electric shock.
- Do not place AC power cord near heat sources. The cord casing may melt resulting in a fire and electric shock.
- When unplugging the AC power cord, always grasp the plug itself and do not pull at the cord; otherwise, this may damage the cord resulting in a fire and electric shock.
- Before maintenance cleaning, unplug the power cord from the AC outlet for safety.
- Use cutting tools and magnets at the number of revolutions recommended by the manufacturer. Do not use it at the number of revolutions beyond the permissible range, since this can result in damage to the device.
- In the case of electric overload, use it after reducing the load since it means the state used in the load beyond setting.

## 2 Equipment Features

### ●Worldwide Power Supply

It is equipped with an AC100~240V-compliant worldwide power supply. Thus, gone are troublesome changes in power-supply settings and failures by voltage differences.

### ●Various Security

It is equipped with a safety security function to constantly monitor the load condition of the main axis, overcurrent to motor, heat generated by power-supply and air pressure.

### ●Others

Four motor spindles are connectable. An operator is able to choose and use one among them optionally. It corresponds to 1,000 ~60,000min<sup>-1</sup> and the wide settings speed of rotations.

## 3 Specifications and Dimensions

### 3-1 Specifications

Model	MT01SP
Electric Power	AC100~240V 50/60Hz
Service Temperature Range	0~40°C
Consumed Electric Power	10W
Air Consumption	120L/min (0.35~0.4MPa x4 set)
Range of RPM setting	500~60,000min <sup>-1</sup> *500min <sup>-1</sup> is the alignment setting.
An effective use range	5,000~60,000min <sup>-1</sup>
Weight	2.9Kg
Dimension	W100mm x D194mm x H230mm
Storage temperature	-10~60°C *Do not use in an environment with heavy condensation.
Storage humidity	10~85% *Do not use in an environment with heavy condensation.

### 3-2 Dimension of External Appearance

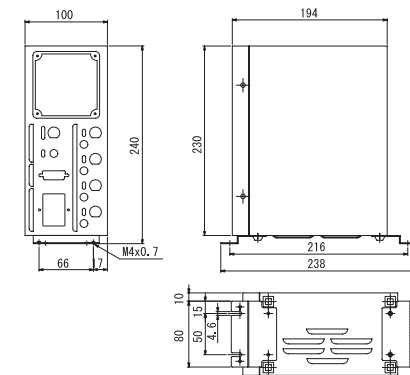

• Fig.-1 Floor mounting type

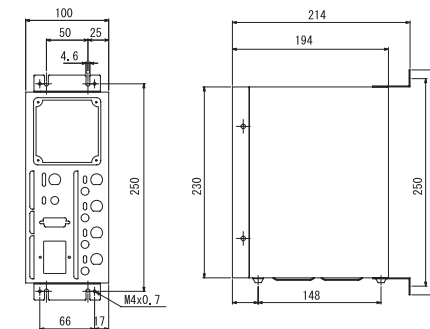

• Fig.-2 Back face mounting type

### 3-3 Accessories

#### AC Power Cord

- ◆CA20 / CA21 / CA22 ※
- ※Either one of them
- ※It is attached to CA20 a 3p→2p adapter.

#### Communication Cord

- ◆MTC-05...1piece

#### Connection Cord

- ◆MSC-05...1piece

#### Air Stop Plug

- ◆MRZ1...4pieces

#### Blackest

- ◆MTB1...2pieces
- ◆MTB2...2pieces

#### Mounting screw

- ◆MRZ3...4pieces

#### Rubber feet

- ◆MRZ2...4pieces

4-1 Overall Configuration

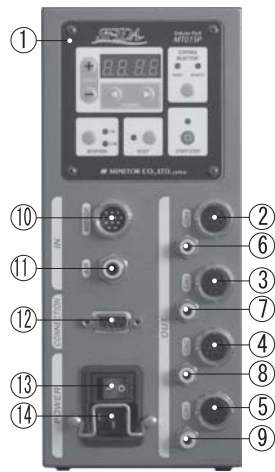

• Fig. -3

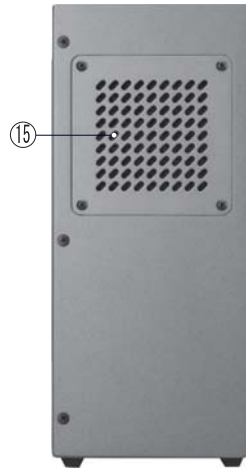

• Fig. -4

① Operation Panel

See "Operation Panel Details"

②③④⑤ Connector for Connecting Motor

For connecting the Spindle connection cord (MC01S or MC01Z).

⑥⑦⑧⑨ AIR OUT Coupler

For connecting air-hose (4mmΦ).

⑩ MOTOR IN Connector

For connecting connector for the motor connecting of Control Pack (MT01CT).  
Connect an attached Selector connection cord (MSC-05).

⑪ AIR IN Coupler

For connecting air-hose (6mmΦ).  
Operating range : 0.18~0.5MPa  
Supply air pressure : Make adjustments to 0.3~0.5MPa

⑫ CONNECTION Connector

For signaling connection to Control Pack (MT01CP).  
Connect an attached Selector Communication cord (MTC-05).

⑬ MAIN Switch

It's the main power switch.

⑭ AC Socket

For plugging AC power cord.

⑮ Filter Panel

The dust proof-filter is built in. Periodical inspection and cleaning of the dust proof-filter are required.

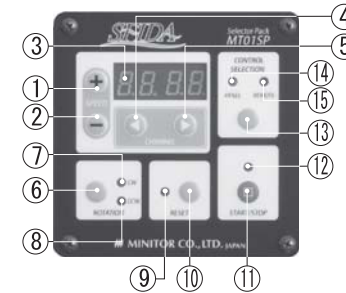

• Fig. -5

① "+" Switch (for increasing the speed of rotation)

When this switch is pushed during panel operation mode, the speed of rotation increases in devices of 1,000 min<sup>-1</sup>. When it is held onto for more than two seconds, the speed of rotation will continue to increase, to a maximum setting of 60,000 min<sup>-1</sup>.

② "-" Switch (for decreasing the speed of rotation)

When this switch is pushed during panel operation mode, the speed of rotation decreases in devices of 1000min<sup>-1</sup>. When it is held onto for more than two seconds, the speed of rotation will continue to decrease, to a minimum setting of 1,000min<sup>-1</sup>.

When the "+" switch is pressed in the indication of 1,000min<sup>-1</sup> at the time of a motor stop, it will be set at 500min<sup>-1</sup> for alignment.

Note: Effective working range is 5,000min<sup>-1</sup> or more.

③ Indicator

The channel number being chosen shall be displayed in the left-hand side. The right-hand side indicates the settings or operation speed of rotation, and also indicates when malfunctions occur by blinking error numbers.

④⑤ Channel-Setting Switch

This switch sets up channels. Every time ⏪ is pushed, the number will be small and will be "4" next to the "1". When ⏩ is pushed, the number will be big and will be "1" next to the "4". It can't be set up during the motor operating and error number displaying.

⑥ ROTATION Switch

This switch sets up the rotation orientation of the motor.

⑦⑧ CW Lamp / CCW Lamp

This lamp lights when the rotation of the motor is set to a clock-wise rotation (CW) and a counter clock-wise rotation (CCW).

⑨ RESET Lamp

This lamp blinks when malfunctions occur in this device and Control Pack etc.

⑩ RESET Switch

This switch cancels the error.

\*Note: When the error number reads the level of No.90, it is unable to cancel the error even if the switch is pushed.  
First, turn off MAIN switch, then turn on after about three minutes to reset the error display.

⑪START/STOP Switch

This switch turns the motor ON or OFF.

⑫START/STOP Lamp

This lamp lights up in accordance with the state of the motor.

(State of motor)	(State of lamp)
During pauses	Red illuminates
During operation → Stop	Red blinks
Operation at fixed speed of rotation	Green illuminates
Operation outside fixed speed of rotation	Green blinks
Error number being displayed	Orange blinks

⑬MODE Switch

This switch changes the operation mode.

⑭PANEL Mode Lamp

This lamp lights when it's in Panel Operation Mode.

⑮REMOTE Mode Lamp

This lamp lights when it is in Remote Operation Mode.

**5** Operating Procedure

5-1 Type of Operation Mode

Three different operation modes are available – to switch mode press the MODE switch while the motor is paused. The mode change in the following order : "Panel Operation Mode" "Panel/Remote Operation Mode" and "Report Operation Mode". When the power is turned on, it returns to the previous operation mode. If the mode changes, all lamps on the operation panel will light up once.

● Panel Operation Mode

This is operated by a switch on this operation panel.

● Panel/Remote Operation Mode

To set the number of rotations, use the operation panel. All other operation settings can be changed using the control connector.

● Remote Operation Mode

This is operated by an external signal from the CONTROL connector of Control Pack.

5-2 Panel Operation Mode

1. Connect connecting cord, transmission cable, air-hose and AC power cord correctly.
2. Turn on the MAIN switch of Control Pack. In the next, turn on the MAIN switch of this device. The indicator of Control Pack continues displaying "S.L." until the MAIN switch of this device turns on.
3. Turning on the MAIN switch of this device shall check the function that every lamp on the operation panel lights out after every lamp lights on.

4. Make sure that the PANEL mode lamp on the operation panel is lit. Since the Control Pack side is automatically Selector Operation Mode at this time, REMOTE mode lamp lights up.
5. Supply air to the motor. Control the amount of air pressure so that about five lamps of LEVEL indicator in the Control Pack and then adjust it in accordance with the exothermic heat condition by details of the task.

\*Note: When the air pressure is too low, the first lamp of the LEVEL Indicator blinks; when too high, every lamp blinks.

6. With a channel-setting switch, set up an access channel.
7. Press the ROTATION switch so that the lamp of intended rotation direction lights up.
8. Press the +(UP) or -(DOWN) switch so that the intended speed of rotation is displayed on the indicator.
9. Press the START/STOP switch to start or stop the motor.

(Functioning of Memory)

Setting data of operation mode, access channel, rotation direction and the speed of rotation of motor are recorded in a memory. Setting data of operation mode and access channel are recorded immediately after change. As for setting data of rotation direction and the speed of rotation of motor, changed data shall be recorded after the motor has stopped. When the MAIN switch is turned on, this device can be operated in the previously set mode.

(Measures for resetting when malfunctions occur)

When malfunctions occur, the indicator displays an error number as "E.-□□" (□ is figures). Stop the motor when the motor is operating. Push RESET switch of this device to reset. Since error "E.-9□" can not be reset, turn off the Control Pack and the MAIN switch of this device once. Fix the cause of the malfunction, and turn on each MAIN switch after about three minutes.

5-3 Panel/Remote Operation Mode

1. Connect connecting cord, Communication cord, air-hose and AC power cord correctly.
2. Turn on the MAIN switch of the Control Pack. In the next, turn on the MAIN switch of this device. An indicator of the Control Pack continues the display of "S.L." till the MAIN switch of this device is turned on.
3. Turning on the MAIN switch of this device shall check the function that every lamp on the operation panel lights out after every lamp lights on.
4. Make sure that the PANEL mode lamp and REMOTE mode lamp on the operation panel are lit. The Control Pack is in the selector operation mode automatically at this moment, and the REMOTE mode lamp lights up in the operation panel.
5. Supply air to the motor. Adjust air pressure so as to light up about five lamps of LEVEL indicator in the Control Pack. After that, adjust air pressure in consideration of the exothermic condition by the contents of work.
6. Turn on or off the external input signal "SELO" and "SEL1" when setting up an access channel. The channel to be used can be set up with the combination of ON and OFF. Complete the setup 100ms before turning on the external START signal.

(Access Channel)	(External SEL 1 Signal)	(External SEL 0 Signal)
1	OFF (0V)	OFF (0V)
2	OFF (0V)	ON (12~24V)
3	ON (12~24V)	OFF (0V)
4	ON (12~24V)	ON (12~24V)

7. When setting up the rotation direction, turn the external ROTATION signal on or off so that LED of the intended rotation direction ("CW" or "CCW") is lit. Complete the setup 100ms before turning on the external START signal.

(Rotation Direction Settings)	(External ROTATION Signal)
CW	OFF (0V)
CCW	ON (12~24V)

8. When trying to set up the motor speed, press the "+" (up) or "-" (down) switch so that the intended number of rotations is displayed in the indicator.
9. Switch the external START signal to turn the motor on or off.

(Operation of motor)	(External START signal)
Stop	OFF (0V)
Start	ON (12~24V)

(Measures for resetting when malfunctions occur)

When malfunctions occur, the indicator displays an error number as "E.-□□" (□ is figures).

Stop the motor when the motor is operating. Turn the external START signal off to reset, and turn on the external RESET signal once and then turn off. Please input the RESET signal after turning off external ROTATION signal, too when F.6 set to "on" by "5-5 Setting of the function".

(Reset operation)	(External RESET signal)
Reset ON	ON (12~24V)
Reset OFF	OFF (0V)

When "E.-9□" is displayed, turn off the MAIN switch of the Control Pack and this device.

Fix the cause of the malfunction, and turn on each MAIN switch after about three minutes in the state of the external START signal OFF.

#### 5-4 Remote Operation Mode

This mode is the same as the "Panel/Remote Operation Mode", except for the method used to change the number of rotations of the motor. When trying to set up the number of rotations, vary the external SPEED signal voltage so that the number of rotations you intend to set up will be displayed in the indicator. The setting of the number of rotations is in proportional to the external SPEED signal voltage.

- SPEED signal voltage range is DC 0V ~12V
- Setting speed of rotation  $60,000 \text{ min}^{-1}(\text{max})/\text{SPEED signal voltage}$  is  $\text{DC9V}(\pm 5\%)/\text{SPEED\_UD} \cdot \text{SPEED\_PULSE}$  signal.

\* It is possible to change settings of the speed during motor operation, but the indicator only displays the speed of motor but doesn't display setup speed.

#### 5-5 Setting of the function

This device is able to set the following functions; e.g. Setting the maximum number of rotations by the motor at  $60,000 \text{ min}^{-1}$  or less.

- F.0 Sets restrictions on the maximum number of rotations.  
Display "on" : This restricts the maximum number of rotations.  
Display "of." : This does not restrict the maximum number of rotations.  
When "on" is selected, the number of rotations by panel operation or an external signal can not be set at more than the preset number of rotations.
- F.1 Sets up the maximum number of rotations(CH1).  
Display "1~60"  $\text{ kmin}^{-1}$   
When "F.0" is in the "on" position, the preset number of rotations will be the maximum.
- F.2 Sets up the maximum number of rotations(CH2).  
Display "1~60"  $\text{ kmin}^{-1}$   
When "F.0" is in the "on" position, the preset number of rotations will be the maximum.
- F.3 Sets up the maximum number of rotations(CH3).  
Display "1~60"  $\text{ kmin}^{-1}$   
When "F.0" is in the "on" position, the preset number of rotations will be the maximum.
- F.4 Sets up the maximum number of rotations(CH4).  
Display "1~60"  $\text{ kmin}^{-1}$   
When "F.0" is in the "on" position, the preset number of rotations will be the maximum.
- F.5 Sets up the signal (voltage and pulse signal) to be used when setting the speed from an external source.  
Display "An" : It will be set up by "SPEED Signal voltage".  
Display "P1" : It will be set up by a signal of either "SPPED\_UD" or "SPEED\_PULSE".  
All the number of rotations of CH1-CH4 become the same.  
Display "P2" : It will be set up by a signal of either "SPPED\_UD" or "SPEED\_PULSE".  
The number of rotations of CH1-CH4 is set in each CH.
- F.6 Sets up a signal starting or stopping a motor.  
Display "on" : Press the "START Signal" switch to rotate the motor in a normal direction, or press the "ROTATION Signal" switch for the reverse direction.  
Display "of." : Press the "START Signal" switch to start or stop the motor, or press the "ROTATION Signal" switch to set up the rotation direction.

Note : Since the function number "F.7","F.8" are not used, it will be displayed as "--"

(Setup Method of Functions)

1. Turn on the MAIN Switch. The operation panel will be displayed on the screen.
2. Push the ⑬ MODE switch while pushing ⑩ RESET switch on the operation panel.
3. It will be in the state where the functional setup can be performed after "F.0" (the function number) is displayed in ③ the indicator.
4. Firstly confirm that "F.0" is being indicated. Then the display of the "F.0" shall flash after having released the MODE switch.
5. When pushing the ①+switch, the indication shall change e.g. "F.0", "F.1", "F.2", "F.3" ... "F.8" and "F.0" in turn, and when pushing the ②- switch, it shall change e.g. "F.0", "F.8", "F.7" ... "F.1" and "F.0" in turn while the display is flashing.
6. The set-up content of the function number will be displayed by pushing the ⑪ START/STOP switch while the function number for presetting is flashing.



7. For changing the set-up contents, push the START/STOP switch while the contents are being displayed to get the state of flashing, and then push either + or - switch to display the contents to be set up
8. When the START/STOP switch has been selected after changing the set-up contents, the modification descriptions will be recorded and the function number will be flashing on the display. When the contents have not been changed, push the RESET switch. the modification descriptions will not be recorded, and it will return to the flashing function number.
9. Return to No.6 above when intending to change the setup of the multiple functions continuously. After finishing the setup, it will return to the state where the MAIN switch is turned on by pressing the RESET switch.

## 5-6 Initialization of Settings

This is the method to return this device to its initial setting.

1. Turn the MAIN switch ON while pushing ⑩ RESET switch and ⑬ MODE switch on operation panel.
2. Let go of the switches when a blinking "y.n" is displayed in the indicator. The "y.n" will blink.
3. If you are trying to initialize settings, push ⑪ START/STOP switch.

(Content of initialization)

Operation mode : Panel operation mode	Setting channel : 1
Number of rotations : 1,000 min <sup>-1</sup>	Setting of the maximum number of rotations : "OFF"
Direction of rotation : "CW"	Setting of the external SPEED: "SPEED Signal"
The maximum number of rotation per respective CH :10,000 min <sup>-1</sup>	Setting of the external START signal : "OFF"

\*If not initializing, it will return to a state in which the MAIN switch is ON when the RESET switch is pushed.

## 6 Connection of the Power Cable



• Fig-6



• Fig-7

1. Connect the AC power cord of accessories to the AC plug ⑭ in the front of this device. (Fig.-6)
2. Fix the connector part with a stopper to prevent disconnecting AC power cord. (Fig.-7)

### ⚠ Warning

This device shall be grounded using the ground wire of the AC power cord. It is essential to connect the ground wire to the earth to avoid an electric shock when using this device. Be sure to use the supplied power cords with earth points. In addition, confirm that the ground wire has been grounded correctly before connecting a cable to the input-output terminal of this device. When disconnecting the AC power cord from the outlet, always grasp the plug itself and not at the cable; otherwise, it could cause a disconnection.

## 7 Connection with a Control Pack (MT01CP)

### 7-1 Connection of Selector Connection Cord (MSC-05)

Connect attached Selector Connection Cord to a connector for the motor connection of a Control Pack and MOTOR IN connector ⑩ of this device. (Fig.-8)

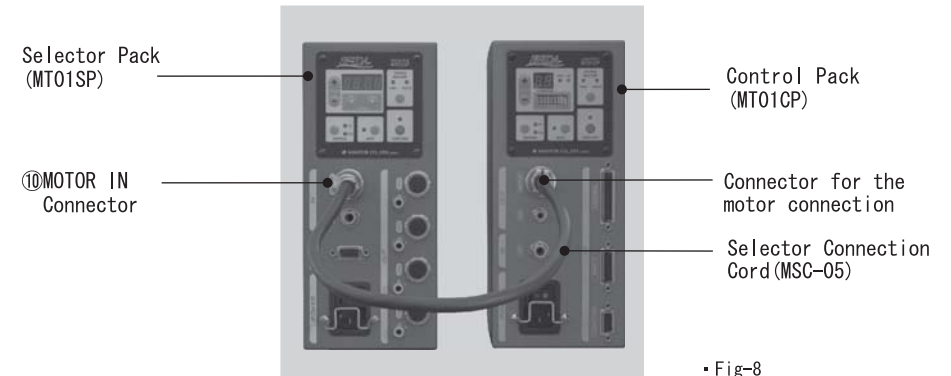

• Fig-8

### 7-2 Fixing of Connecting Cord



Match to a key groove  
Fix with the lock part

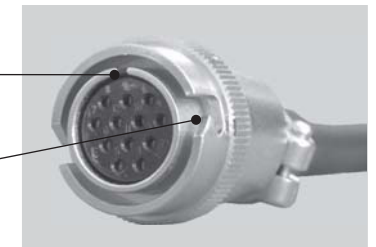

• Fig-9

• Fig-10

1. Connect the plug of attached connecting cord to a connector of ⑩ "MOTOR IN" in the front of this device.
2. Connect the plug (Fig.-10) of a connecting cord to a socket and turn the lock part to fix it.

### ⚠ Caution

Be sure to turn off the MAIN switch of this device when connecting a cord.

### 7-3 Connection of Selector Communication Cord(MTC-05)

Connect the Selector Communication Cord to CONNECTION connector of a Control Pack and CONNECTION connector ⑫ of this device. (Fig.-11)

Tighten the screw of the both plug-ends not to separate from a connector.

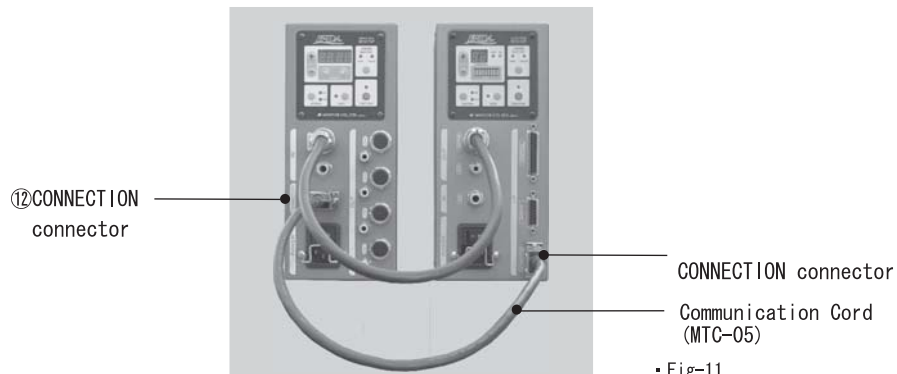

• Fig-11

\* If the transmission cable is connected, a Control Pack shall be automatically set to the selector operation mode.

#### Caution

When connecting the Selector Communication Cord, be sure to use it to only this device and Control Pack. Connecting with equipments other than this series may cause failure or damage.

### 7-4 Connection of the Spindle Connection Cord

1. Connect the plug of Spindle Connection Cord(MC01S, MC01Z) of the spindle (MS01) to connectors (②、③、④ & ⑤) for the motor connection of this device. (Fig.-12) Attach an attached cap to a connector for the motor connection that is out of use.
2. Plug the air hose (6.0mmΦ) from the air supply valve in the AIR IN coupler ⑪ of this device.
3. Connect the air hose (4.0mmΦ) of a spindle (MS01) to the AIR OUT couplers(⑥、⑦、⑧ & ⑨) of this device. Attach an attached cap to the AIR OUT coupler that is out of use.

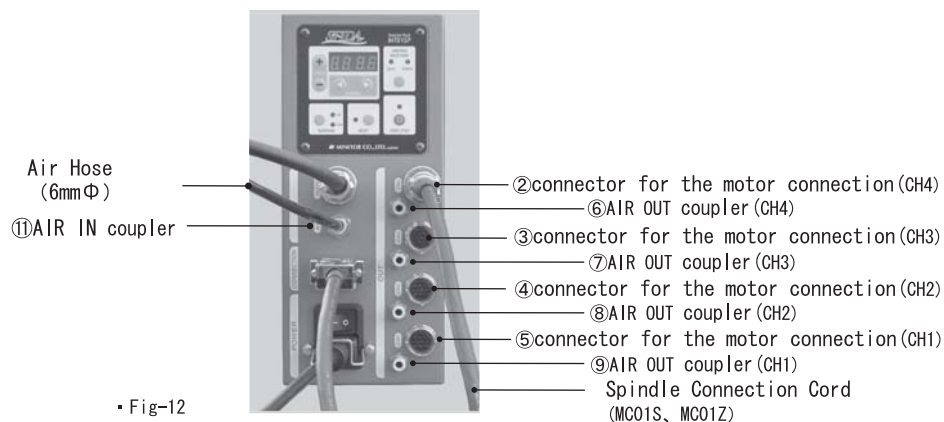

• Fig-12

### 7-5 Connection Diagram of Entire Configuration

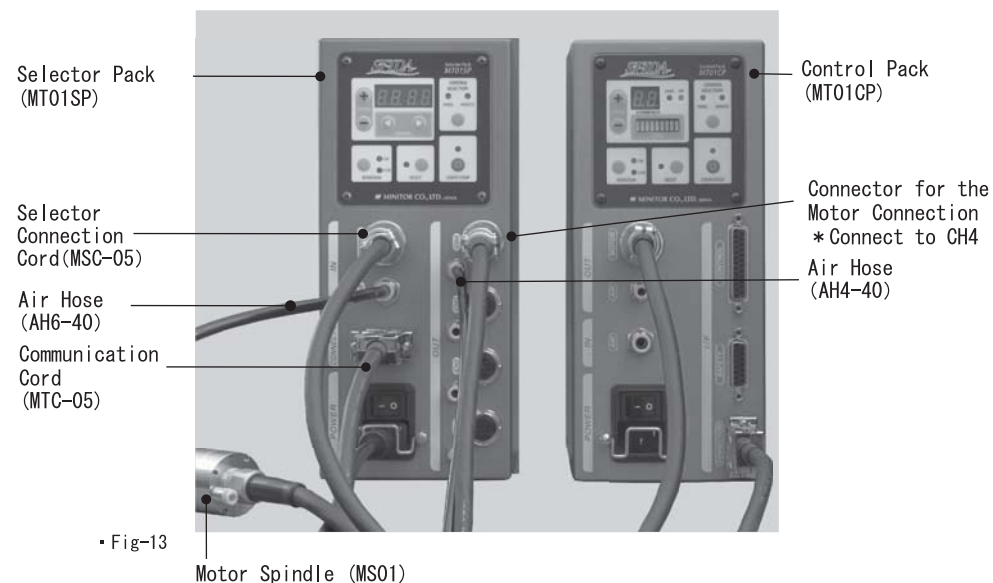

• Fig-13

\*When using the Selector Pack, air supply to the Control Pack is not required.

#### Caution

- Use dry air through the air filter for air supplying to AIR IN coupler.
- The air pressure supplying shall be controlled within 0.3~0.5MPa.
- Be sure the connecting air hose does not have any kinks or acute angle bends. The cooling effect of the motor spindle will be disturbed and it can be the cause degradation and failure.
- Respective connectors for the motor connection and AIR OUT have 4 channels. Attach an attached cap to a connector of channel that is out of use. If a cap is not attached, the powder dust and foreign substances will enter and that can be the cause of failure.
- Be sure to attach an attached cap for the safety reason to each connector that does not use this device and the Control Pack.



## 8 Mounting of Brackets

There are two kinds of bracket accessories.

There are two fixation methods available: the floor type fixation (Fig.-14) and the back mounting (Fig.-15).

Install accessory two brackets for the floor type fixation in the bottom aspect hole of this device.

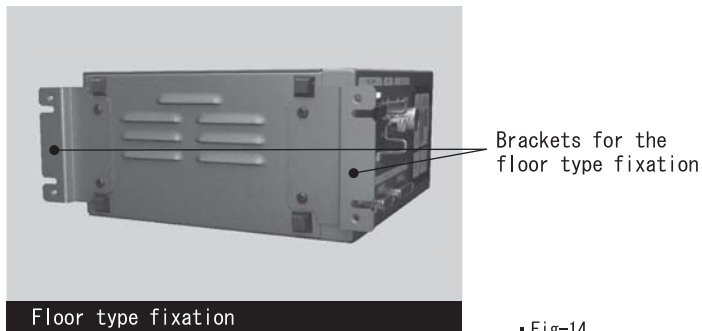

Install accessory two brackets for the floor type fixation in the hole of up-and-down each face of this device back direction.

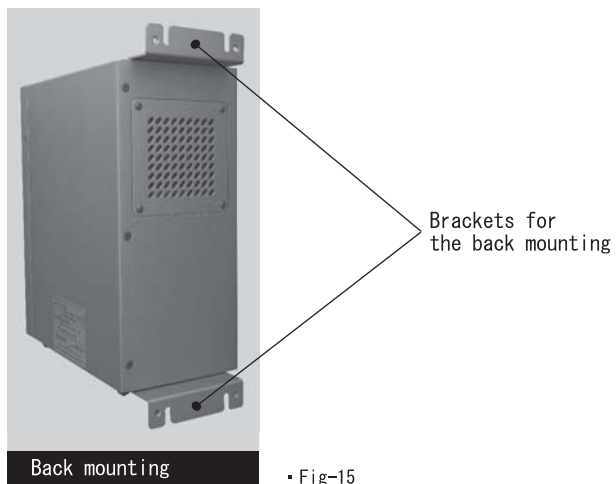

### Caution

Install this device in an environment free from powder, dust and oil.  
For cooling purposes, the air intake on the filter panel surface must be at least 2cm from the installation surface.  
Be careful not to block the slit on the bottom of the chassis, as it needs to expel air.

## 9 Replacement of the Operation Panel

### 9-1 Changing the Mounting Direction of the Operation Panel



The mounting direction of the Operation Panel can be changed vertically or horizontally (Fig.-16). Remove the screws in the four corners when demounting the operation panel. As the need arises, change the direction of the panel. Fix the setting rubber accessories (4 pieces) in the marked positions.

### 9-2 Replacement of the Operation Panel and Filter Panel

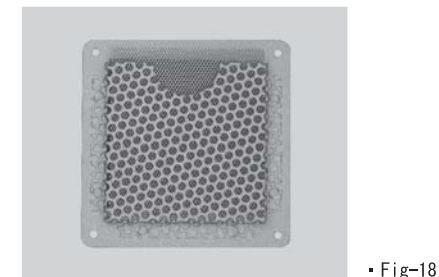

First, remove the Operation Panel and see that the cable is connected from Operation Panel foundation bed to the connector on the main foundation bed of this device. Push-expand each lock-lever attached to the upper part of the connector to the outside direction when removing the connector. The connector for connections on this device foundation bed is mounted respectively on the front and rear faces of the cubicle. As for the connection method, plug the connector in the state that the lock-lever was opened in the right and left, and then close both sides of the lock-lever.

### 9-3 Cleaning of Filter

Since the filter panel is equipped with a dustproof filter, carry out periodic inspection and cleaning. (Fig.-18) When installing the filter panel, turn the filter insertion-opening up.

### Caution

When changing the installation position of the operation panel, be sure to turn off the MAIN switch of this device and perform while AC power cord is unplugged.

10-1 How Error Number Is Displayed

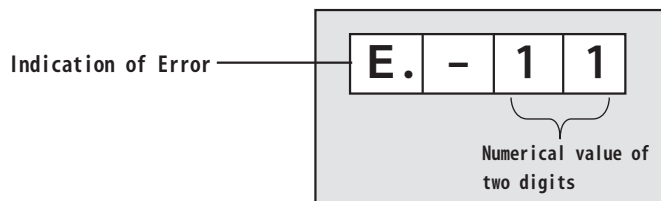

The display of error number is shown on the indicator with the value of two digits after "E.". Refer to "10-3 Error Number and Their Contents" for the error number and their contents.

10-2 When Malfunctions Are Detected

When device is on and malfunctions are detected from storage data, after the previous data setting (Operation mode, access channel, rotation direction and rotation speed) is loaded from the memory, the error numbers "88" or "89" are indicated.

- When Error number indicates "89" :  
 Since malfunction is being detected in data of "operation mode"-setting memory, operation in this case will be carried out in Panel operation mode. Press RESET switch on the panel to change the operation mode to "panel operation mode," set up access channel "1," rotation direction "CW," setting speed of rotation "1,000 min<sup>-1</sup>." Data will be stored in memory and the error will be reset. Ref section 5-6 to return machine to factory settings.
- When Error number indicates "88" :  
 It is displayed when malfunctions of access channel, rotation direction and setting speed of rotation data are detected in Panel Operation mode. When the RESET switch on the panel is pressed, the data of access channel "1," rotation direction "CW" and setting speed of rotation "1,000 min<sup>-1</sup>." Data will be stored in memory and the error will be reset.
- When a malfunction of an error number in the 90s is detected:  
 As far as error numbers in the 90s are concerned, it is impossible to release an error by the RESET switch or the external RESET signal. In this case, turn off the MAIN switches of the Control Pack and this device and turn on again after 3 minutes. In case of an error caused by internal temperature rising in the Control Pack, it takes more than 3 minutes, until the temperature falls down. When a 90s error number is still displayed even after turning the MAIN switch on again, there is a failure.

Note: Error numbers in the 90s may appear for the following reasons:

- ① An error that needs to turn on the MAIN switch again for release
- ② Failure of the power supply
- ③ An emergency stop by the safety-relay

Also, it may be due to the impossibility of cancelling errors by the RESET signal; it is for hazard control as well.

10-3 Error Numbers and Their Contents

No	Meanings
02	Immediately after having turned on the power supply in Remote Operation Mode, the exterior START signal will already be ON.
07	Error was detected in the control pack. (changed to RESTART mode)
08	Error was detected in setting memory data of "Rotation Direction and Speed of Rotation" in the control pack.
09	Error was detected in setting memory data of "Operation Mode" in the control pack.
11	Air pressure for motor cooling is low.
19	Air pressure for motor cooling is high.
22	Abnormal motor connection.
23	The motor can not be activated, or it took at least three seconds before reaching the preset number of rotations.
29	The revolution number has been set too high on the Selector Pack.
39	Over-current protection to the motor was activated.
51	Protection functions of the motor power supply were activated.
59	Transistor for the motor-brake overheated.
61	The speed of rotation does not reach number of revolutions set.
62	The speed of rotation is low at 3000~5000 min <sup>-1</sup> or more than speed of rotation set.
68	Revolution of motor is high at 3000~5000 min <sup>-1</sup> or more than speed of rotation set.
69	Motor rotated at more than 65,000 min <sup>-1</sup> .
81	Communication between this device and Control Pack is unavailable.
82	Immediately after having turned on the power supply in Remote Operation Mode, the exterior START signal will already be ON.
83	Control Pack has not been set in the Selector Operation Mode, or communication with this device is unavailable.
84	Communication with this device is unavailable, or Control Pack has not been set in the Selector Operation Mode.
85	Selector Pack indicates an error number in the 90s.
87	Error was detected in the function of Selector Pack (changed to RESTART mode).
88	Error was detected in setting memory data of "Rotation directions & Speed of Rotation" in Selector Pack.
89	Error was detected in setting memory data of "Operation Mode" in Selector Pack.
91	Protection functions of the motor power supply were activated.
92	Operation panel is not connected, or an operation switch is turned on.
93	Output voltage of power supply for motor is too low.
94	Output voltage of power supply for motor is too high.
95	Stopping the motor took 10 seconds or more.
96	Abnormal output current when motor stopped.
97	Malfunctions were detected in the memory of Selector Pack.
98	Malfunctions were detected in the memory of Control Pack, or Malfunctions were detected with the circuit.
99	The Safety Relay was activated.

(Error Detecting Threshold Value)

Air pressure is the cause:

- When air pressure is less than 0.18Pa.
- When air pressure exceeds 0.5MPa.

Motor current is the cause:

- If the flowing current which exceeds unit-continuum region continues for about 30 seconds.  
 Refer to Motor Spindle MS01 Operation Manual "3-3 Torque Output Characteristics (Fig-2)"
- If the electric current is more than 10.5A and continues for more than 5 seconds.

Power supply for motor driving is the cause:

- When the internal temperature of the motor power supply has risen to more than 85°C.
- When the output exceeds 70V.
- When a malfunction has arisen in the cooling fan.
- When transistor surface temperature for the motor-brake has risen to more than 100°C.